



		<b>Form A</b>
Pilot ID	<b>IAC Unlimited</b>	Flight #

No	Symbol	Cat. No.	K	Total K	Grade	Pos	Remarks	Item	K	Grade
1		8.6.1.1 9.10.6.3 9.1.3.4 9.1.3.6 9.4.3.2	11	<b>53</b>	.			Pos.	40	
			19					Harm.	0	
2		5.2.1.1 9.1.1.3 9.10.5.3	17	<b>40</b>	.			Fig K	Total K	
			10					384	424	
3		7.4.1.1 9.2.3.8	10	<b>25</b>	.			<b>Penalties</b>		
			15					Too Low		
4		8.8.1.1 9.1.1.3 9.9.5.3 9.4.1.3	18	<b>51</b>	.			Too High		
			10					Interruptions		
5		8.4.2.4 9.12.1.5 9.4.1.2	14	<b>29</b>	.			Insertions		
			6					Trg Violation		
6		8.6.4.3 9.4.5.2 9.1.3.6	13	<b>28</b>	.			Wing Rocks		
			5					Disqual Fig		
7		2.3.2.3	37	<b>37</b>	.			Other(note...)		
			10					<b>Final Freestyle</b>		
8		6.2.2.4 9.9.5.4	17	<b>28</b>	.			Duration	Min	Sec
			11							
9		8.6.3.1 9.8.1.1 9.2.3.4 9.1.3.3 9.1.3.7	15	<b>48</b>	.			<b>Judges Details</b>		
			7					Signature		
10		5.3.1.4 9.2.2.4 9.9.5.2	23	<b>45</b>	.			Name		
			11					Number		

\_\_\_\_\_ Pilot  
 ..... A/C



		Form B
Pilot ID	IAC Unlimited	
	Flight #	

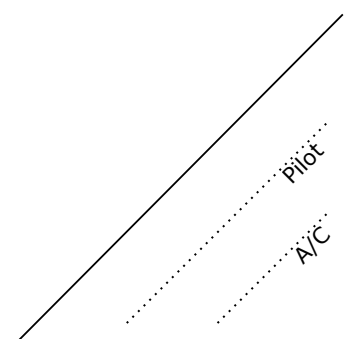
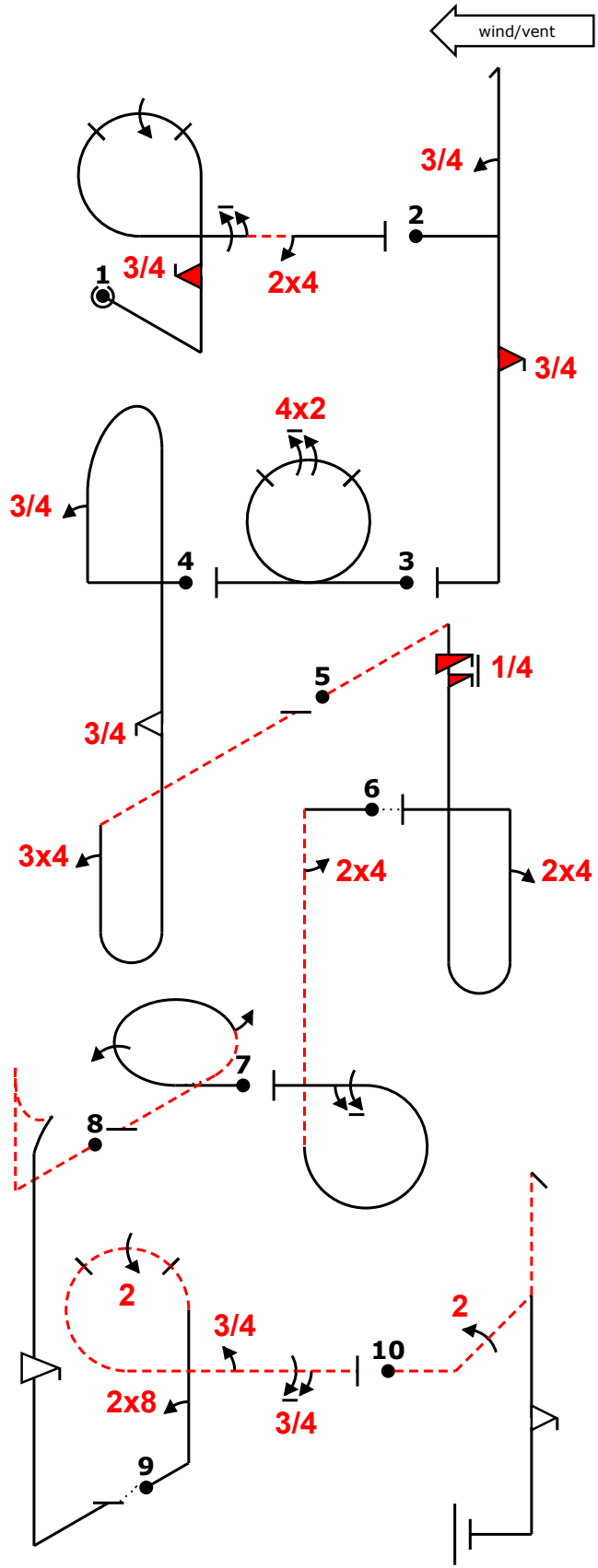



		Form C
Pilot ID	IAC Unlimited	
	Flight #	

