

INTERNATIONAL AEROBATIC CLUB SCORESHEET

A

Contest: U. s. National Championships	Date: 2015	Category: Unlimited	Programme: Unknown1	pilot's number	
--	---------------	------------------------	------------------------	-------------------	--

No	Symbol	Cat. No.	K	Total K	Grade	Remarks	Item	K	Score						
1		7.2.4.1 9.1.3.5 9.1.3.7 9.2.3.8 9.9.3.6	8 9 11 15 14	57			Presentation	20							
2		5.2.1.4 9.1.5.2	22 4	connect 6			FIGURE TOTAL K =		442						
3		7.4.5.1 9.1.2.5 9.8.2.1 9.9.9.4	15 11 5 13	44			INC. PRESENTATION =		462						
4		8.6.3.1 9.8.1.1 9.1.1.3 9.10.3.4 9.1.3.3 9.4.3.3	15 7 10 13 6 8	59			Aircraft type:								
5		8.4.4.2 9.1.1.1 9.1.5.1	14 6 2	connect 6			FREE PROGRAM CHECKED BY: <table border="1" style="width: 100%; height: 100%; border-collapse: collapse;"> <tr> <td style="width: 33%; height: 100px; vertical-align: bottom;">Signature:</td> <td style="width: 33%; height: 100px; vertical-align: bottom;">Printed Name:</td> <td style="width: 33%; height: 100px; vertical-align: bottom;">Date:</td> </tr> <tr> <td style="height: 50px;"> </td> <td style="height: 50px;"> </td> <td style="height: 50px;"> </td> </tr> </table>			Signature:	Printed Name:	Date:			
Signature:	Printed Name:	Date:													
6		8.4.15.1 9.1.2.2 9.10.2.4 9.2.4.4	12 6 15 9	42											
7		7.4.3.1 9.9.8.2 9.8.3.2	14 13 7	34											
8		8.8.2.1 9.1.1.1 9.1.1.1	19 6 6	connect 6											
9		7.4.1.3 9.1.3.8	14 12	26											
10		8.8.8.3 9.1.5.2 9.1.1.1	19 4 6	connect 6											
11		8.6.1.1 9.10.6.3 9.2.3.4 9.1.3.4	11 19 9 8	47											
12		7.4.1.1 9.8.3.4	10 15	25											
13		5.2.1.1 9.4.1.3 9.1.5.4	17 12 8	37											
14		8.6.2.1 9.1.1.5 9.4.3.4 9.1.3.6	12 14 11 10	47											

Judge Name:

IAC #

Assistant Name:

IAC #



Unlimited FU#1 B
 Pilot
 A/C



B	Contest:	U. s. National Championships	Category:	Unlimited
	Date:	2015	Program:	Unknown1
			Pilot's No.	<input type="text"/>

Pilot: Unlimited FU#1 B

wind direction

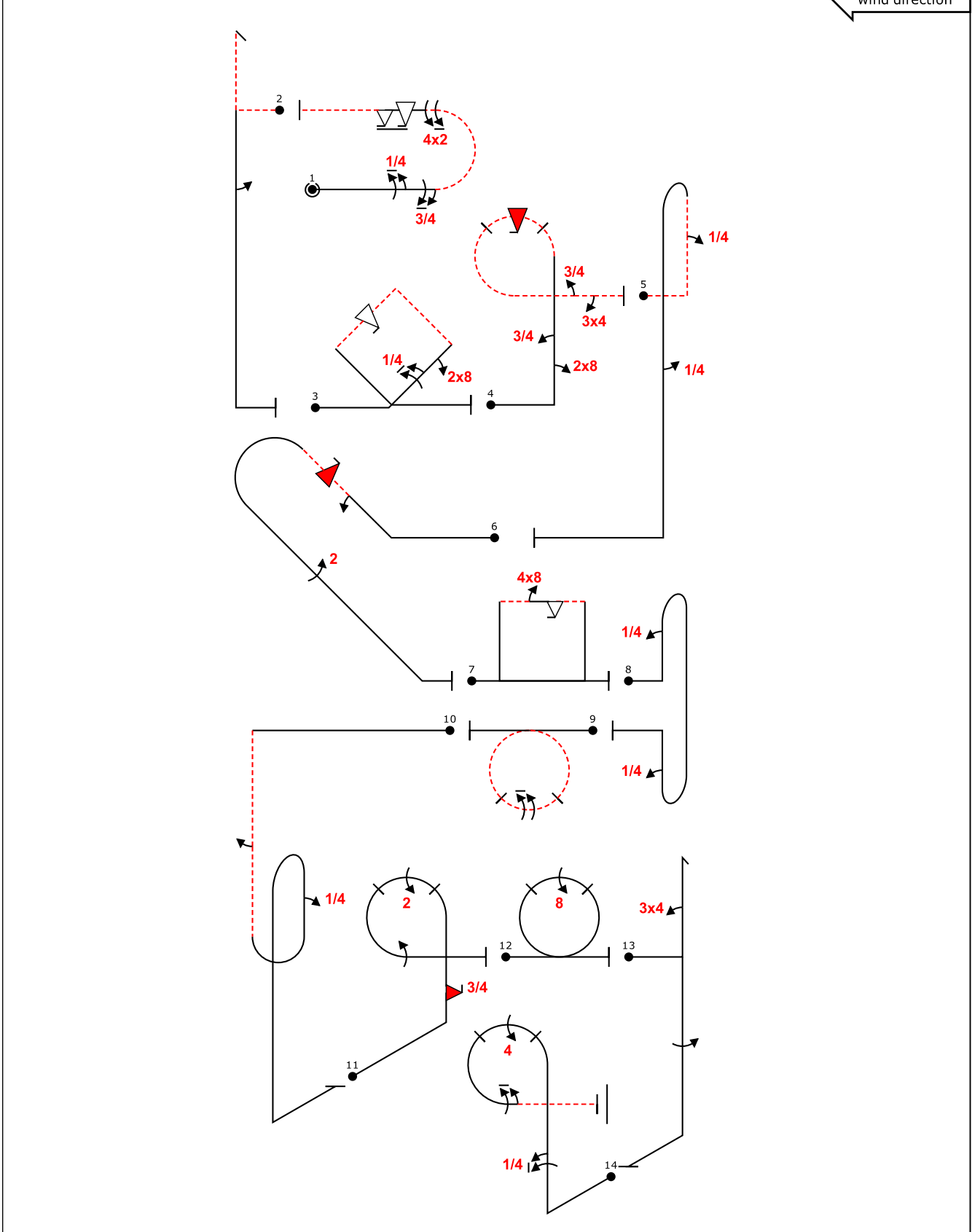

A/C:

(signature/date)

FREE PROGRAM CHECK BY:



C	Contest: U. s. National Championships	Category: Unlimited
	Date: 2015	Program: Unknown1

Pilot: Unlimited FU#1 B

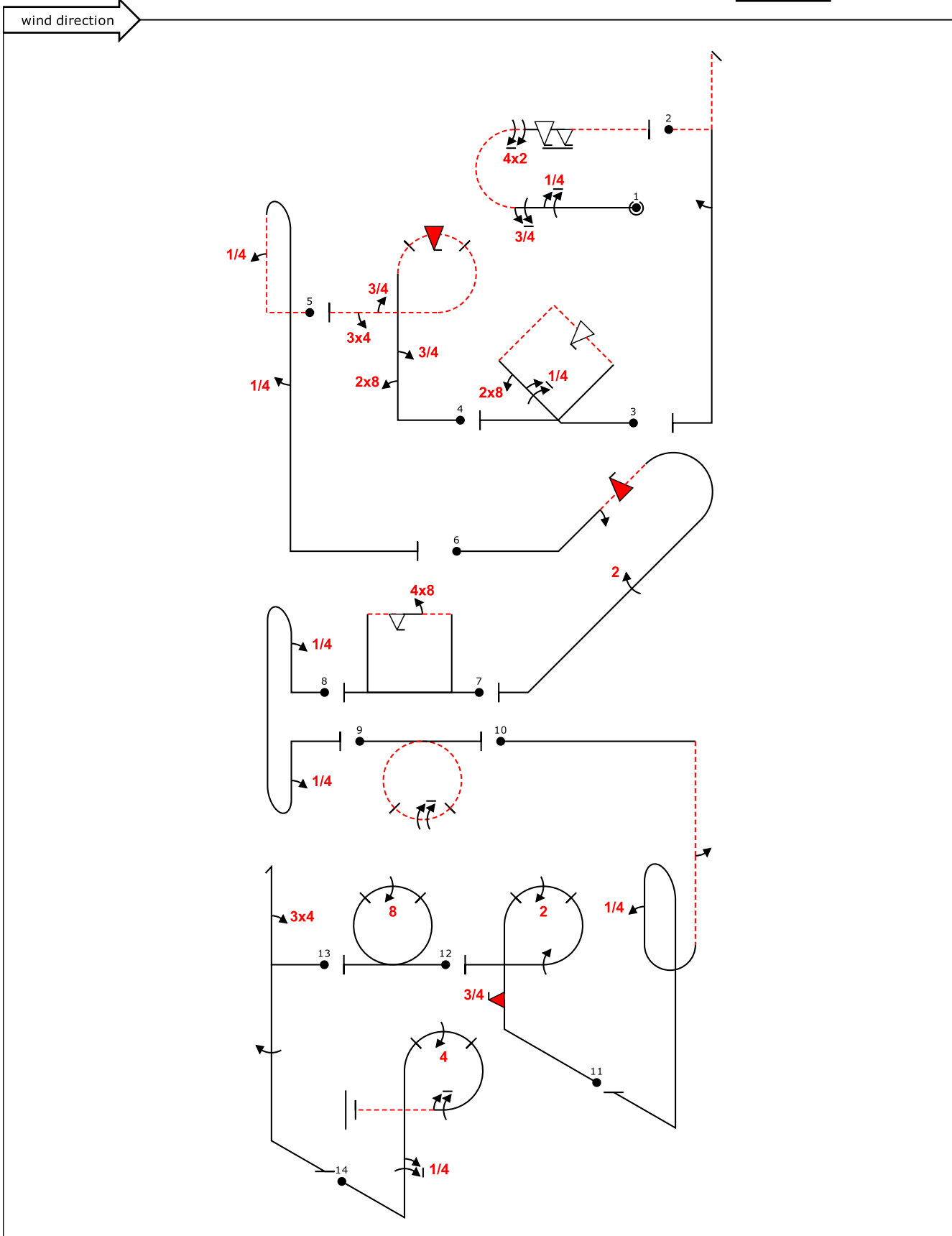

A/C: _____
FREE PROGRAM CHECK BY: _____ (signature/date)