



US NATS, Salina, KS 2024

Form A

Pilot ID

CIVA Unlimited Free Known

Flight #

No	Symbol	Cat. No.	K	Total K	Grade	Pos	Remarks	Item	K	Grade
1		5.3.2.1 9.1.2.6 9.1.5.6	24 12 10	<b>46</b>	•			Pos.	40	
								Harm.	0	
2		1.3.14.1 9.1.1.2 9.1.4.4 9.1.4.8	22 8 8 12	<b>50</b>	•			Fig K	Total K	
								450	490	
<b>Penalties</b>										
3		8.8.1.4 9.12.1.4 9.1.5.1 9.1.5.3	18 7 2 6	<b>33</b>	•			Too Low		
								Too High		
4		6.2.1.1 9.1.1.5 9.9.5.3	15 14 11	<b>40</b>	•			Interruptions		
								Insertions		
5		1.3.11.1 9.2.1.4 9.10.4.5 9.1.4.3 9.1.1.4	20 13 15 6 12	<b>66</b>	•			Trg Violation		
								Wing Rocks		
6		8.8.3.4 9.1.5.2 9.8.1.1 9.1.5.5	20 4 7 9	<b>40</b>	•			Disqual Fig		
								Other(note...)		
<b>Final Freestyle</b>										
7		5.3.1.1 9.2.2.4 9.1.1.1 9.9.5.5	18 11 6 13	<b>48</b>	•			Duration	Min	Sec
<b>Judges Details</b>										
8		8.4.3.1 9.4.1.3 9.10.5.3	15 12 13	<b>40</b>	•			Signature		
								Name		
								Number		
9		7.5.2.1 9.4.3.4 9.1.4.6 9.2.3.6 9.9.3.6	15 11 10 12 14	<b>62</b>	•					
10		2.2.5.4	25	<b>25</b>	•					

Mike Galloway Pilot  
EA-3005 N540BG A/C



US NATS, Salina, KS 2024

Form B

Pilot ID

CIVA Unlimited Free Known

Flight #

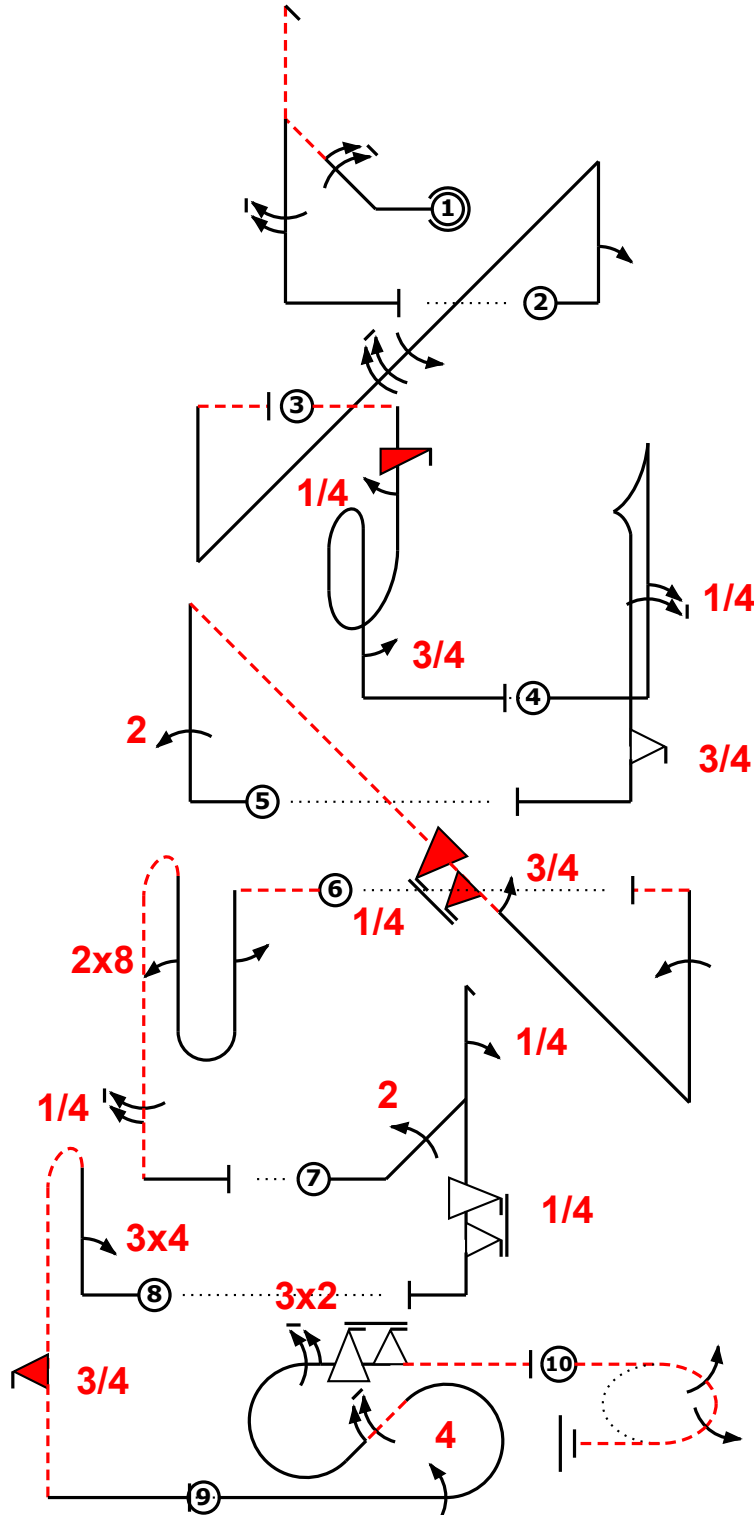
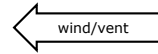

Mike Gallaway Pilot  
EA-300S N540BG A/C



US NATS, Salina, KS 2024		Form C
Pilot ID	CIVA Unlimited Free Known	Flight #

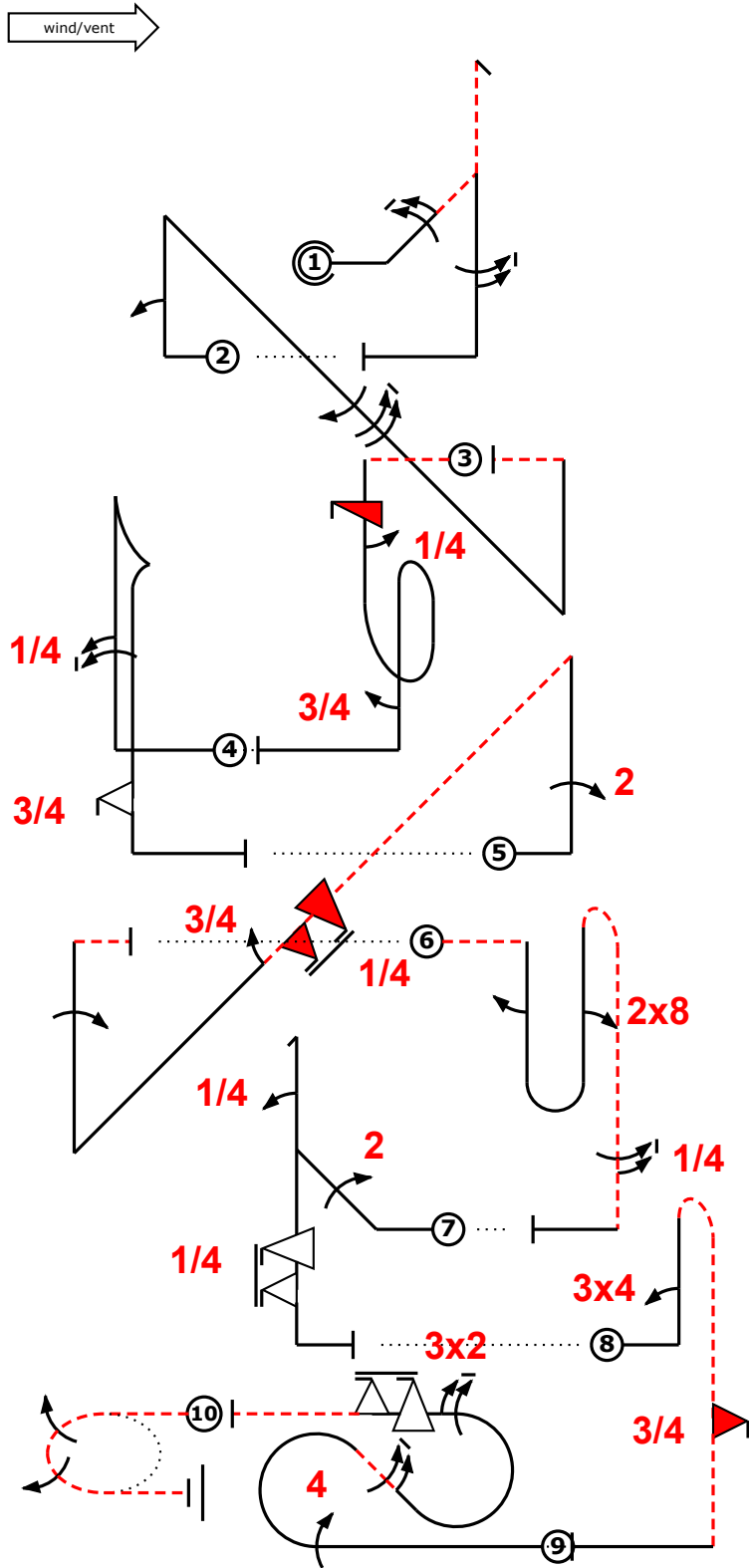

*Mike Galloway* Pilot  
EA-300S N540BG A/C



CIVA Unlimited 2024  
 Free Known US NATS, Salina, KS

wind/vent ← **R**

Figure K  
**450**  
 Total K  
**490**

Judges Name  
 Signature Number

Flight #

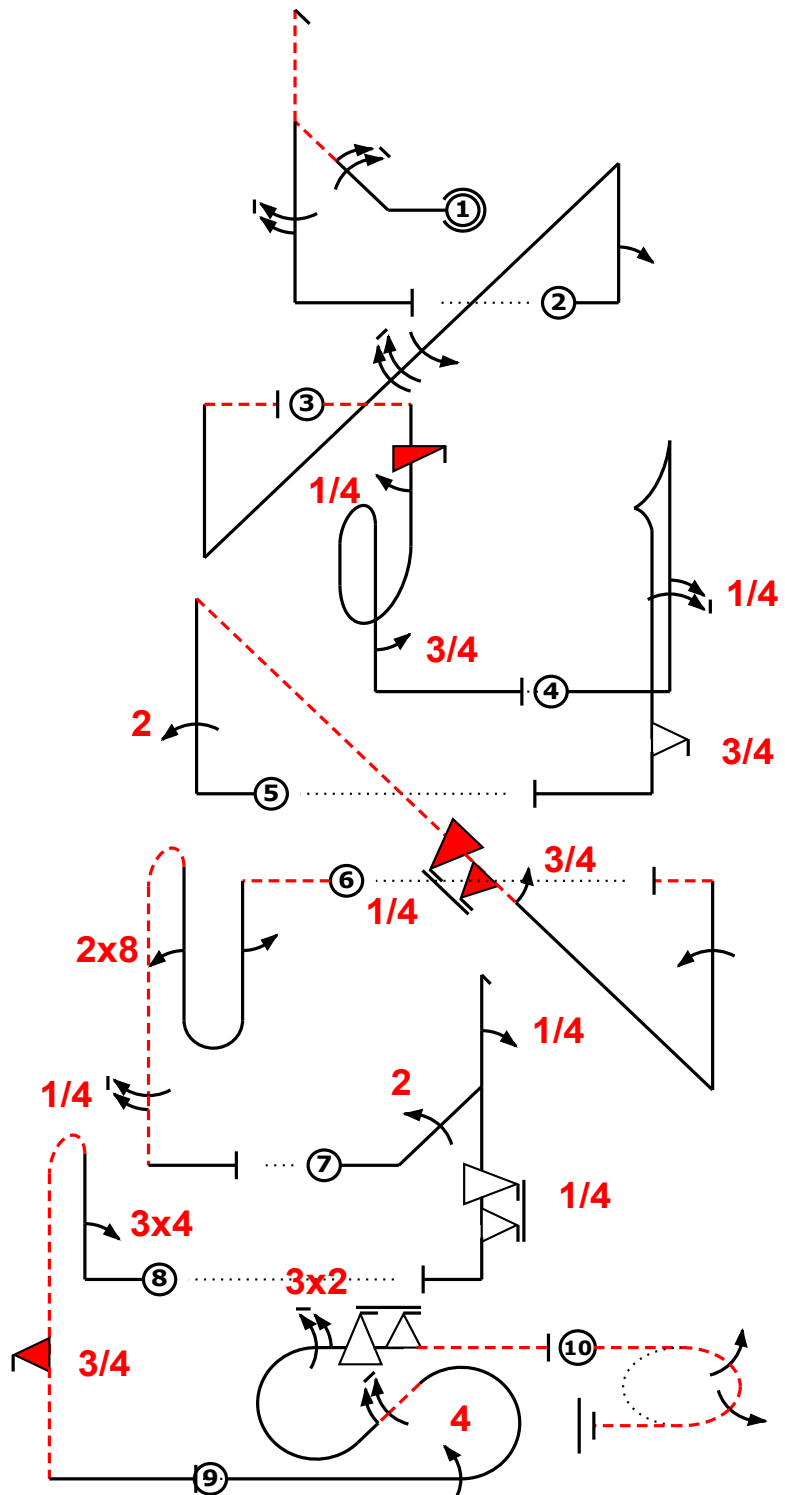

Fig	Grade	Pos	Remarks
1	.		
2	.		
3	.		
4	.		
5	.		
6	.		
7	.		
8	.		
9	.		
10	.		

Positioning  
**40**

Too Low		Trg Violation	
Too High		Wing Rocks	
Interruptions		Disqual Fig	
Insertions		Other(note...)	

Fig 1	K	Fig 2	K	Fig 3	K	Fig 4 B	K	Fig 5 C	K	Fig 6	K	Fig 7 A	K	Fig 8	K	Fig 9 D	K	Fig 10 E	K
5.3.2.1	24	1.3.14.1	22	8.8.1.4	18	6.2.1.1	15	1.3.11.1	20	8.8.3.4	20	5.3.1.1	18	8.4.3.1	15	7.5.2.1	15	2.2.5.4	25
9.1.2.6	12	9.1.1.2	8	9.12.1.4	7	9.1.1.5	14	9.2.1.4	13	9.1.5.2	4	9.2.2.4	11	9.4.1.3	12	9.4.3.4	11		
9.1.5.6	10	9.1.4.4	8	9.1.5.1	2	9.9.5.3	11	9.10.4.5	15	9.8.1.1	7	9.1.1.1	6	9.10.5.3	13	9.1.4.6	10		
		9.1.4.8	12	9.1.5.3	6			9.1.4.3	6	9.1.5.5	9	9.9.5.5	13			9.2.3.6	12		
								9.1.1.4	12							9.9.3.6	14		
<b>SF 5</b>	<b>46</b>	<b>SF 7</b>	<b>50</b>	<b>SF 7</b>	<b>33</b>	<b>SF 6</b>	<b>40</b>	<b>SF 7</b>	<b>66</b>	<b>SF 7</b>	<b>40</b>	<b>SF 5</b>	<b>48</b>	<b>SF 7</b>	<b>40</b>	<b>SF 7</b>	<b>62</b>	<b>SF 2</b>	<b>25</b>

Pilot: Mike Gallaway

A/C: EA-300S N540BG

Team: USA



CIVA Unlimited 2024  
Free Known US NATS, Salina, KS

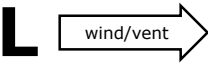

Figure K  
450  
Total K  
490

Judges Name  
Signature Number

Flight #

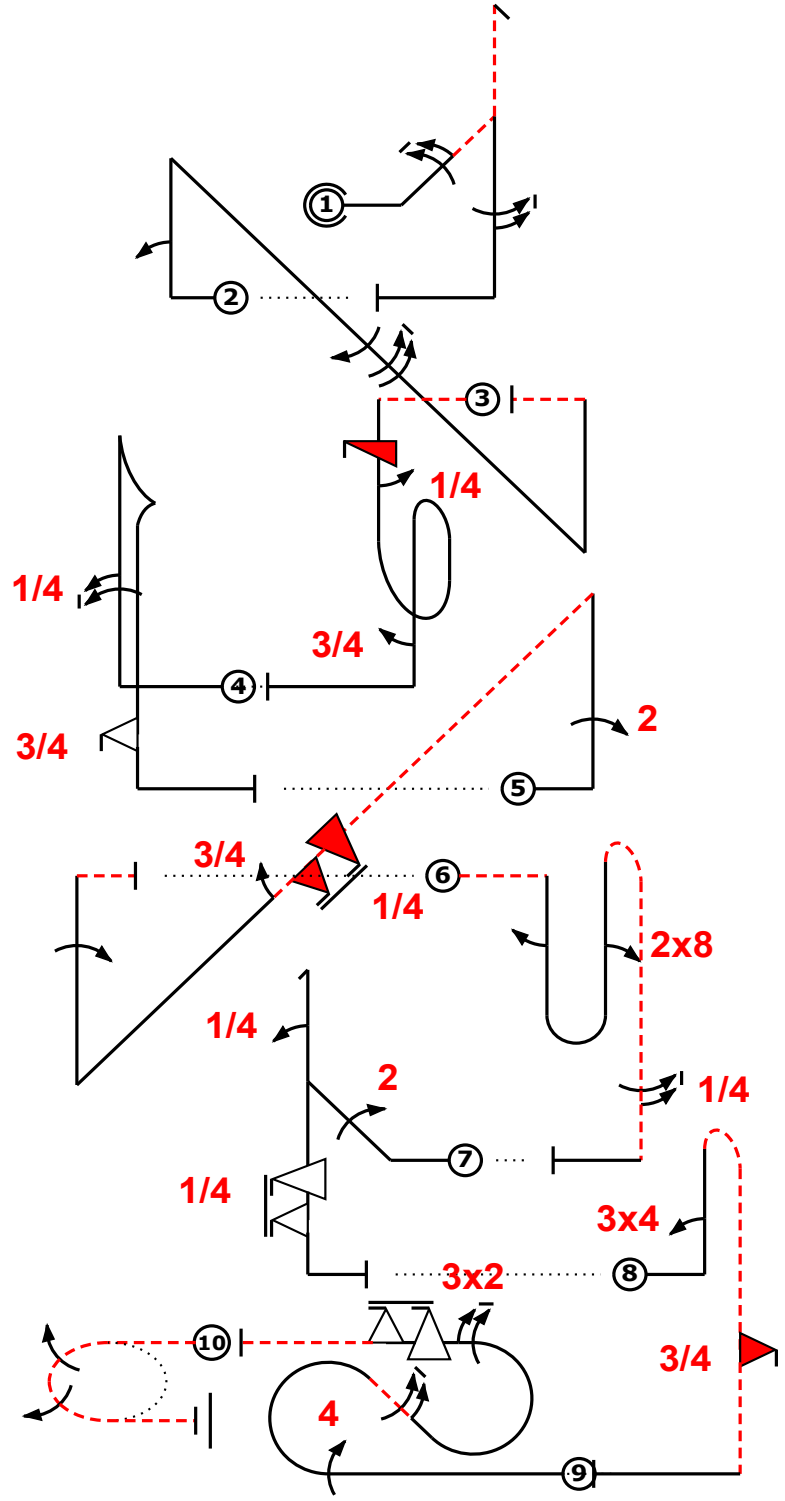

Fig	Grade	Pos	Remarks
1	.		
2	.		
3	.		
4	.		
5	.		
6	.		
7	.		
8	.		
9	.		
10	.		

Positioning  
40 .

Too Low		Trg Violation	
Too High		Wing Rocks	
Interruptions		Disqual Fig	
Insertions		Other(note...)	

Fig 1	K	Fig 2	K	Fig 3	K	Fig 4 B	K	Fig 5 C	K	Fig 6	K	Fig 7 A	K	Fig 8	K	Fig 9 D	K	Fig 10 E	K
5.3.2.1	24	1.3.14.1	22	8.8.1.4	18	6.2.1.1	15	1.3.11.1	20	8.8.3.4	20	5.3.1.1	18	8.4.3.1	15	7.5.2.1	15	2.2.5.4	25
9.1.2.6	12	9.1.1.2	8	9.12.1.4	7	9.1.1.5	14	9.2.1.4	13	9.1.5.2	4	9.2.2.4	11	9.4.1.3	12	9.4.3.4	11		
9.1.5.6	10	9.1.4.4	8	9.1.5.1	2	9.9.5.3	11	9.10.4.5	15	9.8.1.1	7	9.1.1.1	6	9.10.5.3	13	9.1.4.6	10		
		9.1.4.8	12	9.1.5.3	6			9.1.4.3	6	9.1.5.5	9	9.9.5.5	13			9.2.3.6	12		
								9.1.1.4	12							9.9.3.6	14		
SF 5	46	SF 7	50	SF 7	33	SF 6	40	SF 7	66	SF 7	40	SF 5	48	SF 7	40	SF 7	62	SF 2	25

Pilot: Mike Gallaway

A/C: EA-300S N540BG

Team: USA

wind/vent ←

