







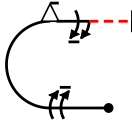
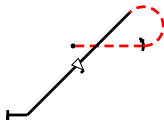

INTERNATIONAL AEROBATIC CLUB SCORESHEET

A

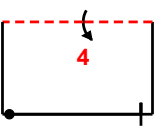
Contest:	Date: 2024	Category: Power Advanced	Programme: Unknown	pilot's number	
----------	----------------------	--	------------------------------	-------------------	--

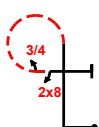
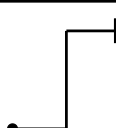
No	Symbol	Cat. No.	K	Total K	Grade	Remarks	Item	K	Score
1		5.3.1.1 9.1.1.1 9.9.5.3	18 6 11	35			Presentation 30 <div style="border: 1px solid black; padding: 2px; margin-top: 5px;">FIGURE TOTAL K = 273</div> <div style="border: 1px solid black; padding: 2px; margin-top: 5px;">INC. PRESENTATION = 303</div> <div style="border: 1px solid black; padding: 2px; margin-top: 5px;">Aircraft type:</div> <div style="border: 1px solid black; padding: 5px; margin-top: 10px; display: flex; justify-content: space-between;"> <div style="writing-mode: vertical-rl; transform: rotate(180deg);">FREE PROGRAM CHECKED BY:</div> <div style="width: 60%; border-right: 1px solid black; padding-right: 5px;">Signature:</div> <div style="width: 20%; border-right: 1px solid black; padding-right: 5px;">Printed Name:</div> <div style="width: 20%; padding-right: 5px;">Date:</div> </div> <div style="border: 1px solid black; padding: 2px; margin-top: 10px;">Judge Name:</div> <div style="border: 1px solid black; padding: 2px; margin-top: 2px;">IAC #</div> <div style="border: 1px solid black; padding: 2px; margin-top: 10px;">Assistant Name:</div> <div style="border: 1px solid black; padding: 2px; margin-top: 2px;">IAC #</div> <div style="text-align: center; margin-top: 20px;">  </div> <div style="text-align: right; margin-top: 20px;"> <i>Pilot</i> <i>A/C</i> </div>		
2		7.2.1.1 9.1.3.8 9.9.3.2 9.1.3.6	6 12 11 10	39					
3		8.5.5.2 9.1.3.4 9.9.4.4	12 8 11	31					
4		5.2.1.1 9.4.1.2 9.4.5.2	17 9 5	31					
5		7.4.3.1 9.4.3.4	14 11	25					
6		8.4.1.1 9.8.1.1 9.1.5.3	13 7 6	26					
7		8.6.4.1 9.1.3.3 9.8.3.1	14 6 3	23					
8		1.1.6.1	10	10					
9		1.1.6.3 9.11.1.6	10 3	13					
10		7.2.2.1 9.1.3.4 9.1.3.2	6 8 4	18					
11		2.2.5.1	22	22					

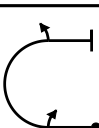
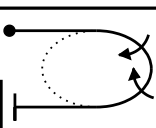

B	Contest:	Category:
	Date: 2024	Program: Unknown

Pilot: _____

wind direction

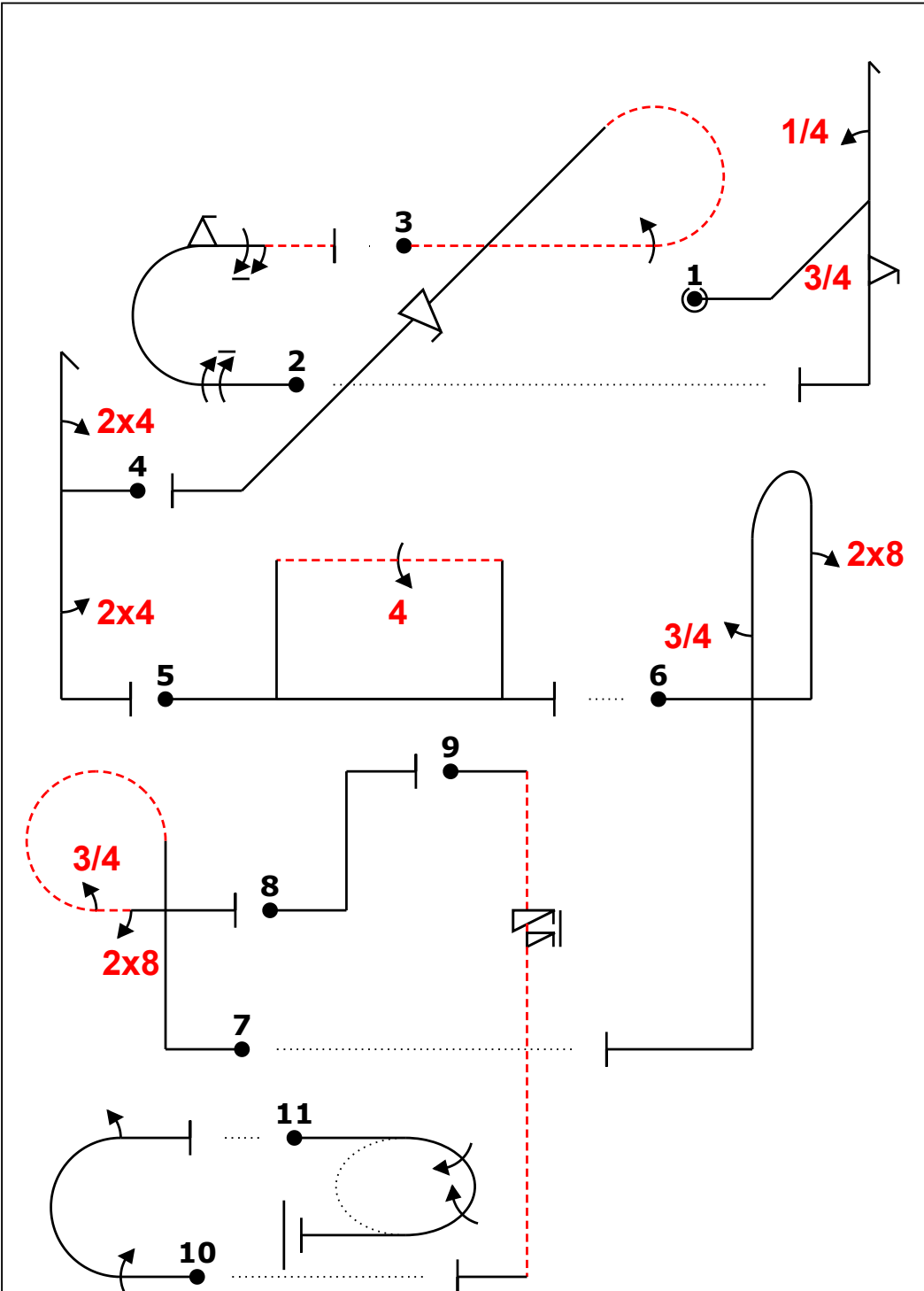

Power			
Fig	Aresti	K	
1	5.3.1.1	18	35
	9.1.1.1	6	
	9.9.5.3	11	
2	7.2.1.1	6	39
	9.1.3.8	12	
	9.9.3.2	11	
	9.1.3.6	10	
3	8.5.5.2	12	31
	9.1.3.4	8	
	9.9.4.4	11	
4	5.2.1.1	17	31
	9.4.1.2	9	
	9.4.5.2	5	
5	7.4.3.1	14	25
	9.4.3.4	11	
6	8.4.1.1	13	26
	9.8.1.1	7	
	9.1.5.3	6	
7	8.6.4.1	14	23
	9.1.3.3	6	
	9.8.3.1	3	
8	1.1.6.1	10	10
9	1.1.6.3	10	13
	9.11.1.6	3	
10	7.2.2.1	6	18
	9.1.3.4	8	
	9.1.3.2	4	
11	2.2.5.1	22	22
Total K = 273		(max K = 275)	

A/C:

(signature/date)

FREE PROGRAM CHECK BY:



C	Contest:	Category: Power Advanced
	Date: 2024	Program: Unknown

Pilot: _____

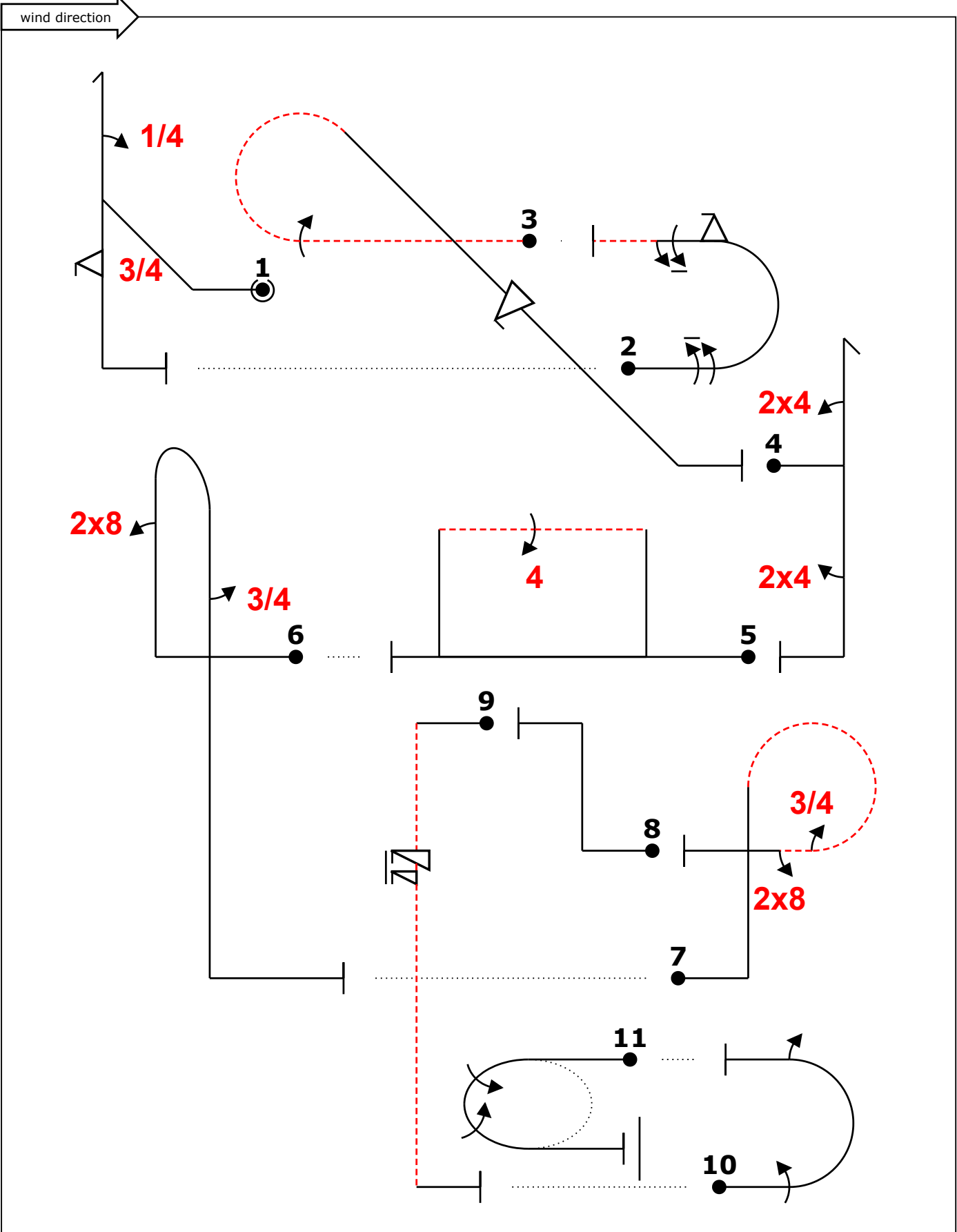

A/C: _____

(signature/date)

FREE PROGRAM CHECK BY: _____